

Thank you for purchasing this AgfaPhoto digital camera. Please read these operating instructions carefully in order to use the digital camera correctly. Keep the instructions in a safe place after reading so that you can refer to them later.

Precautions

- Do not aim the camera directly into the sun or other intense light sources which could damage your eyesight.
- Do not try to open the case of the camera or attempt to modify this camera in any way. High-voltage internal components create the risk of electric shock when exposed. Maintenance and repairs should be carried out only by authorized service providers.
- Do not press the flash too close to the eyes of animals or young children. Eye damage may result. Please remain at least one meter away from infants when using flash.
- Keep the camera away from water and other liquids. Do not use the camera with wet hands. Never use the camera in the rain or snow. Moisture creates internal danger and may cause electric shock.
- Keep the camera and its accessories out of the reach of children and animals to prevent accidents or damage to the camera.
- If you notice smoke or a strange odor coming from the camera, turn the power off immediately. Take the camera to the nearest authorized service center for repair. Never attempt to repair the camera on your own.
- Use only the recommended power accessories. Use of power sources not expressly recommended for this equipment may lead to overheating, distortion of the equipment, fire, electrical shock or other hazards.

Disclaimer

We assume no responsibility over and above the provisions of the Product Liability Law for damages suffered by the user or third parties as a result of inappropriate handling of the product or its accessories, or by their operational failure and by their use. We reserve the right to make changes to this product and its accessories without prior notice.

Warning!

Never disconnect to open the camera or remove any parts of it. This will invalidate all guarantee claims.

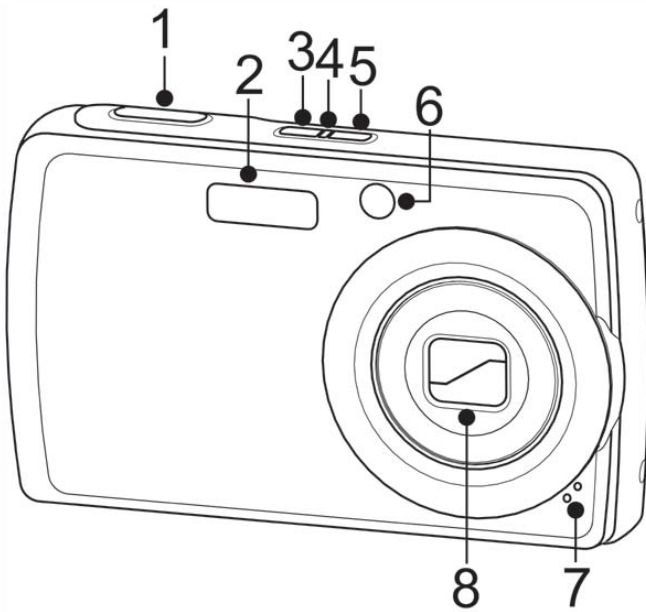

- 1. Shutter button
- 2. Flash
- 3. Stabilizer
- 4. LED indicator
- 5. Power button
- 6. Self-timer LED / AF Assist Lamp
- 7. Microphone
- 8. Zoom Lens

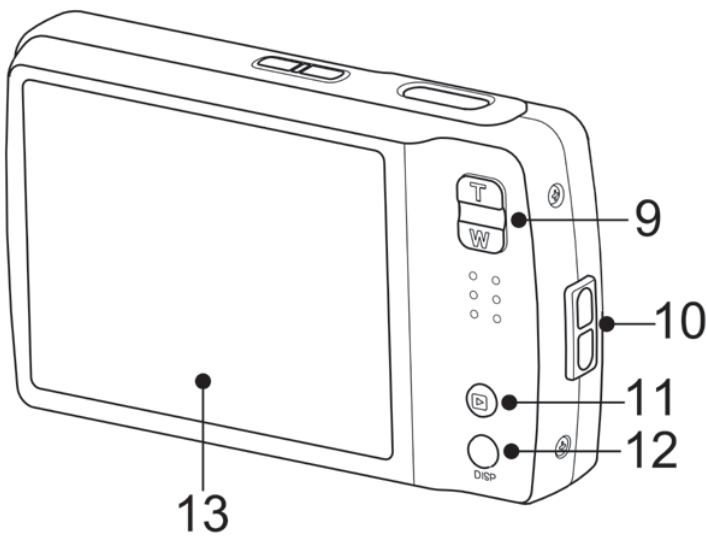

- 9. Zoom buttons
- 10. Strap ring
- 11. Playback button
- 12. DISP buttons
- 13. LCD screen

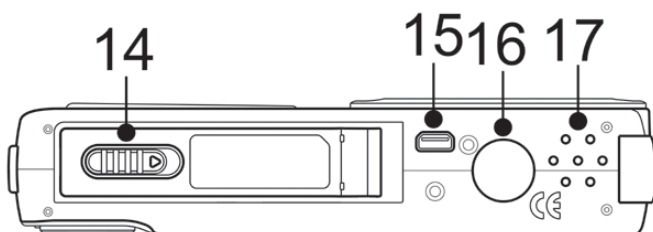

- 14. Battery/ SD card compartment
- 15. USB / TV Out
- 16. Tripod screw hole
- 17. Speaker

Insert the battery

The camera is powered by a rechargeable lithium-ion battery (Li-Ion 820 mAh).

1

Open the battery cover.

- Slide the battery cover in the direction indicated by the arrow.

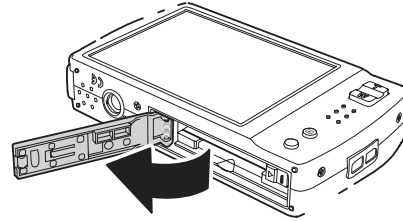

2

Insert the batteries.

- Install the battery with the terminal facing inside the camera.

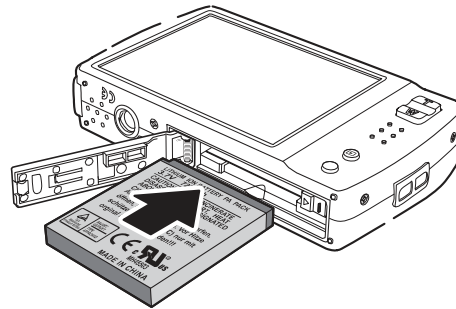

3

Close the battery cover.

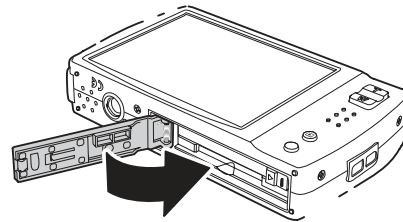

Initial Settings

When you turn on your camera for the first time, you will be asked to do the initial settings of your camera. When you turn the Power button on, the Language Menu is displayed on the LCD screen for you to setup the display language.

Setting the Language

1

Tap  ,  to move through the selection.

2

Tap  to select language.

Using Quick-Set Bar

The **Quick-Set Bar** acts as a shortcut menu to adjust basic settings in Record and Playback Mode. The menu icons show the current settings for each function. The icons vary depending on the selected mode and its settings.

Tap  to launch Quick-Set Bar.

Tap  to close Quick-Set Bar.

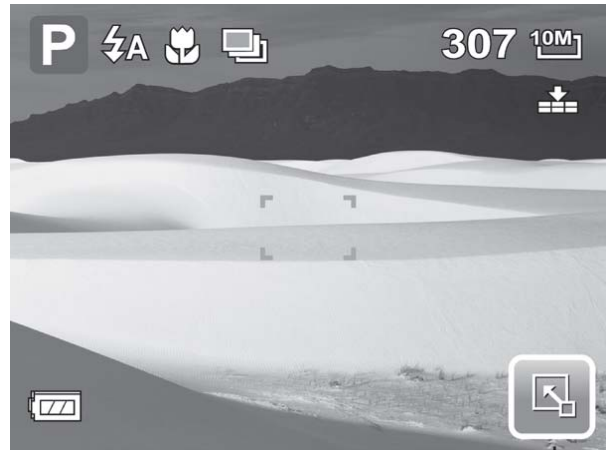



Quick-Set Bar icon

Setting Snapshot Menu

The Snapshot menu allows you to adjust other capture settings. Some menu functions may be disabled depending on current scene mode.

In Snapshot mode,

1 Tap  >  > .

2 Tap  or  to move to the next/ previous page of menu selection.

3 To select an item, tap the icon.

4 To change the submenu settings, tap the icon of desired settings.

5 Tap  to exit submenu.

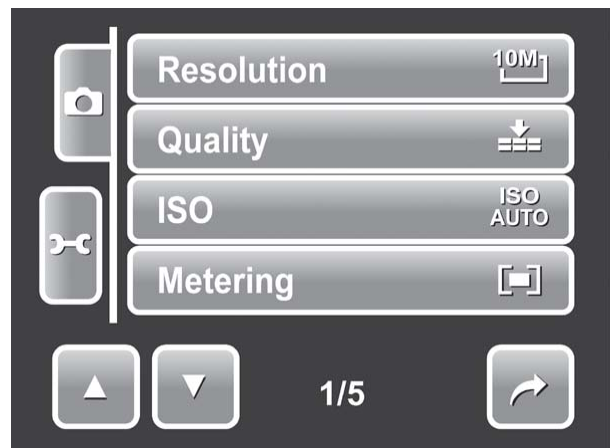

Setting Playback Menu



To go to Playback Menu

The Playback menu allows you to edit images, delete files, records voice memo, and setup other playback settings.

1

Tap  >  > .

2

Tap  or  to move to the next/previous page of menu selection.

3

To select an item, tap the icon.

4

To change the submenu settings, tap the icon of desired settings.

5

Tap  to exit submenu.



Using the Setting Menu



To go to Setting Menu

You can access the Setting menu whether you are in Record or Playback mode. The Setting menu allows you to configure general camera settings. Submenu options may vary depending on the current mode. Unavailable are disabled.

1

Tap  >  > .

2

Tap  or  to move to the next / previous page of menu selection.

3

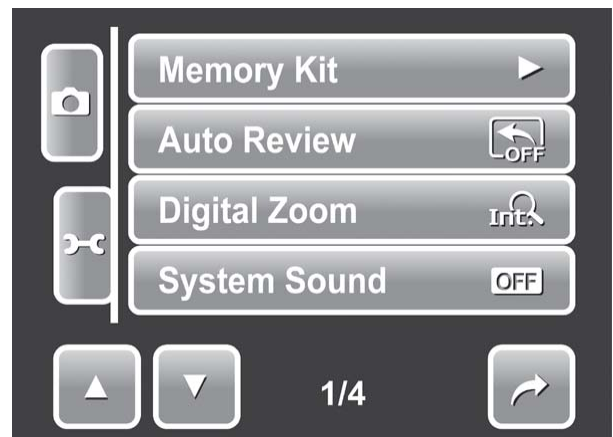

Customer care

More information on the complete AgfaPhoto digital camera product range can be found under www.plawa.com / www.plawausa.com

Service & Repair (USA/ Canada):

1-866 475 2605

www.plawausa.com

Support Service (USA/ Canada)

support-apdc@plawausa.com

Service & Repair Hotline (EU):

00800 752 921 00 (from a landline only)

Service & Support Hotline (Germany):

0900 1000 042 (1.49 Euro/ min. from a German landline only)

Online Service / International contact (Not for USA/ Canada):

support-apdc@plawa.com

Manufactured by

plawa-feinwerktechnik GmbH & Co. KG

Bleichereistraße 18

73066 Uhingen

Germany

AgfaPhoto is used under license of Agfa-Gevaert NV & Co. KG. Agfa-Gevaert NV & Co. KG. does not manufacture this product or provide any product warranty or support. For service, support and warranty information, contact the distributor or manufacturer. Contact: AgfaPhoto Holding GmbH, www.agfaphoto.com.

To return a product, you will need an RMA number which must be clearly visible on the returned shipment. You can find further information on the return of goods either by phoning our Support Hotlines or via the plawa website under the Menu item "Service & Support".

Disposal of Waste Equipment by Users in Private Households in the European Union



This symbol on the product or on its packaging indicates that this product must not be disposed of with your other household waste. Instead, it is your responsibility to dispose of your waste equipment by handing it over to a designated collection point for the recycling of waste electrical and electronic equipment. The separate collection and recycling of your waste equipment at the time of disposal will help to conserve natural resources and ensure that it is recycled in a manner that protects human health and the environment. For more information about where you can drop off your waste equipment for recycling, please contact your local city office, your household waste disposal service or the shop where you purchased the product.

FCC Compliance and Advisory

This device complies with Part 15 of the FCC Rules. Operation is subject to the following two conditions: 1.) this device may not cause harmful interference, and 2.) this device must accept any interference received, including interference that may cause unsatisfactory operation. This equipment has been tested and found to comply with the limits for a Class B peripheral, pursuant to Part 15 of the FCC Rules. These limits are designed to provide reasonable protection against harmful interference in a residential installation. This equipment generates, uses, and can radiate radio frequency energy and, if not installed and used in accordance with the instructions, may cause harmful interference to radio communication. However, there is no guarantee that interference will not occur in a particular installation. If this equipment does cause harmful interference to radio or television reception, which can be determined by turning the equipment off and on, the user is encouraged to try to correct the interference by one or more of the following measures.

- Reorient or relocate the receiving antenna.
- Increase the separation between the equipment and receiver.
- Connect the equipment to an outlet on a circuit different from that to which the receiver is connected.
- Consult the dealer or an experienced radio/TV technician for help.

Any changes or modifications not expressly approved by the party responsible for compliance could void the user's authority to operate the equipment. When shielded interface cables have been provided with the product or when specified additional components or accessories have elsewhere been designated to be used with the installation of the product, they must be used in order to ensure compliance with FCC regulations.